

DOUBLE SHEAR FIXTURE

Apparatus meets fastener testing requirements for NASM1312-13

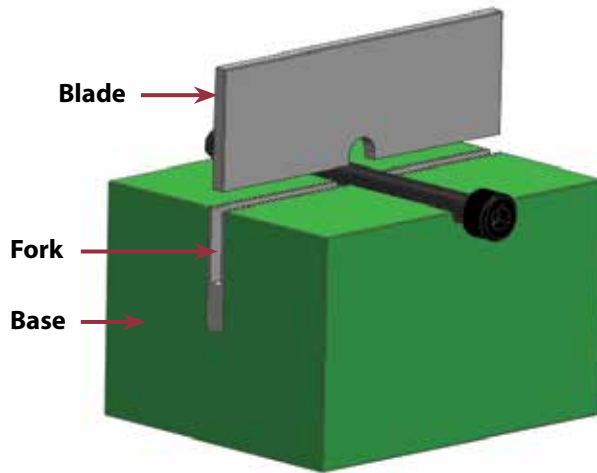

- ▶ *Made of M2 and SKD11 hardened tool steel.*
- ▶ *Available as set (blade, fork, and base).*
- ▶ *Available for fastener diameters 0.125" through 1.5".*
- ▶ *All components are precision machined and matched for each thread size.*
- ▶ *Volume discounts available.*

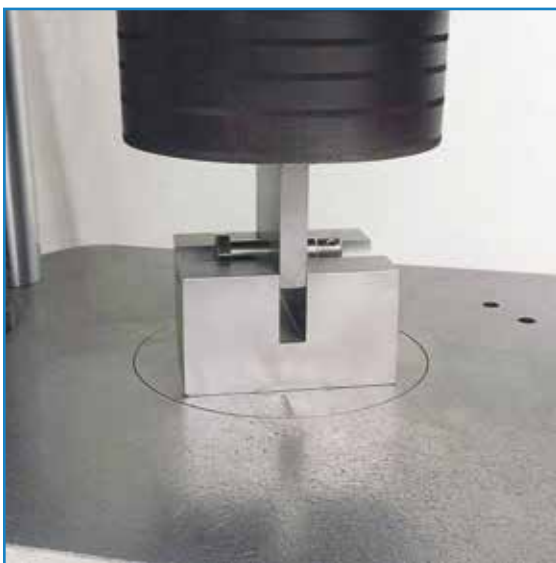

The double shear fixture is designed so the lower portion is supported by the machine table as a controlled, compressive load is put on the fastener. When the force is applied, a shear force at two fastener points is created. Complete procedure and apparatus for testing is specified in NASM1312-13.